



SERVICE MANUAL

MULTI CHANNEL AM/FM TRANSCEIVER

TCB-1100

TTI Tech Co.,Ltd.

TABLE OF CONTENTS

SECTION 1 SPECIFICATIONS

SECTION 2 CIRCUIT DESCRIPTION

2-1 GENERAL

2-2 TECHNICAL DESCRIPTION

2-3 SEMICONDUCTORS AND FUNCTION

2-4 DESCRIPTION OF FREQUENCY DETERMINING AND STABILIZING CIRCUIT

2-5 TEST EQUIPMENT SETUP AND ALIGNMENT INSTRUCTIONS

SECTION 3 PART LIST

SECTION 4 MECHANICAL DISASSEMBLY

SECTION 5 BOARD LAYOUT

5-1 MAIN PCB

5-2 LCD PCB

5-3 LED PCB

5-4 VOLUME PCB

5-5 SQUELCH PCB

5-6 CHANNEL PCB

SECTION 6 BLOCK DIAGRAM

SECTION 7 SCHEMATIC

SECTION 1. SPECIFICATIONS

General

Channel	40 (See the frequency band
Frequency Range	chart)
Operating mode	26.96 MHz 27.99125 MHz
Frequency Control	F3E (FM), A3E (AM)
Frequency Tolerance	PLL Synthesizer
Operating Temperature Range	0.002%
	-10 to + 55 °C
Microphone	Plug-in Type
Input Voltage	13.2V DC ±15%
Size	190(W) x 165(L) x 58(H)
Weight	978.5 g

Transmitter

Power Output	Duty cycle 10% 4 Watts @13.8V
Modulation	DC
	AM:from 85%_to 95%
Frequency Response	FM:1.8KHz to +2.0KHz
Output Impedance	300Hz to 3000Hz
Harmonic Suppression	50ohms, Unbalanced
Current Drain	Less than -36dBm

Receiver

Receiving System	Dual conversion superheterodyne
IF Frequencies	Double Conversion 1st 10.695MHz/2nd 455KHz
Sensitivity	0.7 μV for 10dB(S+N)/N in AM Mode
	0.7 μV for 20dB SINAD in FM Mode
Audio Output Power	2.0W @ 8 Ohm
Audio Distortion	Less then 8% @ 1KHz
Image Rejection	60 dB
Adjacent Channel Rejection	60 dB
	Less than -57dBm
Conducted Spurious Frequency Response	300 to 2500Hz
	8 Ohms, round
Built-in Speaker	Adjustable; Threshold less than 1 microvolt DSS; Less than 2 microvolt

SECTION 2. CIRCUIT DESCRIPTION

----- Contents -----

- 1 General
 - 1-1. Receiver
 - 1.2. Transmitter
- 2. Technical Description
 - 2-1. General
 - 2-2. Type of emission
 - 2-3. Frequency Table
 - 2-4. RF Power Output
 - 2-5. DC input Voltage and Current with 13.2V DC Input to Power AMP
 - 2-6. Receiver IF and Local Oscillator Frequencies
- 3. Semiconductors and Function
- 4. Description of Frequency Determining and Stabilizing Circuit
 - 4-1. Introduction
 - 4-2. Basic Synthesis Scheme
 - 4-3. Descriptions of Each Block
 - 4-3-1. Introduction
 - 4-3-2. Reference Frequency
 - 4-3-3. VCO
 - 4-3-4. Programmable Divider and Its Control
 - 4-3-5. Phase Detector and VCO Control
 - 4-3-6. Transmitter / Receiver Buffer AMP
 - 4-3-7. Transmitter Buffer Amp
 - 4-3-8. Switching of Turning Capacitor in VCO
 - 4-3-9. Receiver Local Oscillator Outputs
 - 4-4. Frequency Stability
 - 4-5. Description of other Circuits
 - 4-5-1. Transmitter
 - 4-5-2. Receiver
- 5. Test Equipment Setup and Test Procedure with Alignment Instructions
 - 5-1. General Section.
 - 5-1-2. Test Procedure with Alignment
 - 5-2. T ransmitter Section
 - 5-2-2. Test Procedure and Alignment at TX
 - 5-3. Receiver Section
 - 5-3-2. Test Procedure and Alignment at RX

1. General

1-1. Receiver

Display : 40 Channels and other functions indication

Frequency Range : 26.965 to 27.405 [MHz]

Frequency Response : 300 to 2,500 [Hz]

Power Source : 13.2 [V] DC

Audio Output Load : 8 [OHM]

Audio Output : 4.0 [W] (or More)

Squelch : Adjustable from 0.2[uV] to 100 [uV]

Sensitivity :

- FM : 20 dB [SINAD] under 1.0 [uV] RF Signal or less
- AM : 10 dB [S/N] under 1.0 [uV] RF Signal or less

Intermediate Frequency :

- 1st IF : 10.695 [MHz]
- 2nd IF : 455 [KHz]

1-2. Transmitter

Carrier Power(Conducted) : AM 4 [W] / FM 4 [W]

Current Drain (13.2 [V] Supply Voltage)

- No Modulation : 1,100 [mA]
- Max Modulation : 1,600 [mA]

Modulation Capabilities

- AM : ± 90 [%]
- FM : ± 1.8 [KHz/Dev]

Spurious Radiation : Less than -54 [dBm]

Antenna Impedance : 50 [OHM]

Frequency Tolerance : 0.002 [%]

2. Technical Description

2-1. General

Model TCB-1100 is an mobile type AM/FM radio transceiver for use of the Citizen Radio Service.

- Front Panel Controls
 - (1) LCD (Channel and RX/TX).
 - (2) Receiver Audio Control Volume (With Power ON/OFF Control)
 - (3) Squelch Control Volume (With DSS ON/OFF Control)
 - (4) Channel UP/Down Rotary Switch
 - (5) CH9 Select Key / Menu Key
 - (6) Scan Key / S.MEM Key
 - (7) DW Key / Vox Key
 - (8) Comp Key / Tone Key
 - (9) Back Light Select Key / Lock Key
 - (10) AM,FM Key / M Key

- Accessorily Connectors
 - (1) Antenna Socket
 - (2) External Speaker Jack (3.5mm)
 - (3) External S-meter Jack (2.5 mm)
 - (4) Microphone Connector (6 pin)

2-2. Type of emission : AM(A3E) , FM(F3E)

2-3. Frequency Table

Channel	Frequency (MHz)	Channel	Frequency (MHz)
1	26.965	21	27.215
2	26.975	22	27.225
3	26.985	23	27.235
4	27.005	24	27.245
5	27.015	25	27.255
6	27.025	26	27.265
7	27.035	27	27.275
8	27.055	28	27.285
9	27.065	29	27.295
10	27.075	30	27.305
11	27.085	31	27.315
12	27.105	32	27.325
13	27.115	33	27.335
14	27.125	34	27.345
15	27.135	35	27.355
16	27.155	36	27.365
17	27.165	37	27.375
18	27.175	38	27.385
19	27.185	39	27.395
20	27.205	40	27.405

2-4. RF Power Output

- AM : 4.0 [W]
- FM : 4.0 [W]

2-5. DC Input Voltage and Current with 13.2V DC Input to Power AMP

- Transmitter Power Amp : Voltage 12.0 V
Current 900 mA
- Transmitter Driver Amp : Voltage 12.0 V
Current 130 mA

2-6. Receiver IF and Local Oscillator Frequencies

- First IF : 10.695 [MHz]
- Second IF : 455 [KHz]
- First Local Oscillator : 10.695 [MHz] Upper Receiving Frequency
- Second Local Oscillation : 10.240 [MHz]

3. Semiconductors and Function

3-1. Transistor

Ref No.	Description	Manufacturer	Function
Q101	2SC4226	NEC	RX Amplifier
Q102	KTK211	KEC	1'st Mixer
Q103	KTK211	KEC	1'st Mixer
Q107	KTC3875S	KEC	RX,RF/Mute,at-TX
Q108	KTC3875S	KEC	AGC
Q109	KTC3875S	KEC	AGC
Q110	KRC112S	KEC	S-Meter Dectector
Q112	KRC112S	KEC	FM AF Mute at AM Mode
Q118	KRC111S	KEC	RX AF Mute at TX Mode
Q114	KTC3880S	KEC	AM IF Amplifier
Q115	KTC3880S	KEC	AM IF Amplifier
Q113	KRA101S	KEC	RX AM(B+)switch
Q116	KTA1504S	KEC	Automatic Noise Level Control
Q111	KTC3875S	KEC	RX FM AF Amp
Q121	KTC1241	KEC	TX,AM/1W-SW
Q132	KRC111S	KEC	TX,AM-AF,SW
Q201	KRC101S	KEC	AF Mute
Q117	KRC111S	KEC	AF Path
Q120	KTA1504S	KEC	Automatic Level Control
Q119	KTC3875S	KEC	Automatic Level Control
Q128	2SC4226	NEC	VCO
Q129	KTC3880S	KEC	RX/TX VCO Buffer
Q130	KTC3880S	KEC	VCO Buffer
Q127	KRC101S	KEC	TX VCO Control
Q133	KRC111S	KEC	TX,Call Switching
Q125	KRC101S	KEC	TX Band2 Switching
Q155	KRC111S	KEC	TX,Mode Switching
Q146	KTC3875S	KEC	FM TX AF Mute at AM TX
Q134	KTC3880S	KEC	TX,Buffer
Q135	KTC3880S	KEC	TX Pre-Amplifier
Q136	2SC2314F	SANYO	TX Driver Amplifier
Q138	RD16HHF1	Mitsubishi	TX Power Amplifier
Q153	KTA101S	KEC	TX SW
Q8	KRC404	KEC	CPU Reset
Q152	KRC101S	KEC	RX/TX Control
Q154	KRA101S	KEC	TX,SW
Q122	KRC101S	KEC	FM,AM,Switch
Q154	KRA101S	KEC	TX,Switch
Q151	KRC111S	KEC	AM/FM,SW
Q145	KRC102S	KEC	Power Low Control
Q143	KTC3875S	KEC	8.2V Regulator
Q142	KTC3875S	KEC	RX B+
Q141	KRA1504S	KEC	TX,B+
Q144	KTC3875S	KEC	5V.Regulator
Q147	KRC111S	KEC	TX,Call-SW

Q1	KTA1505S	KEC	Back-Light,LED-Control
Q2	KRC101S	KEC	Back-Light,LED-Control
Q3	KRC101S	KEC	Back Light LED Control
Q4	KRC101S	KEC	Back Light LED Control
Q5	KRC110S	KEC	Back Light,LED Control

3-2. IC

Ref No.	Description	Manufacturer	Function
IC1	SL5019	AUK	IF IC
IC2	KIA358F	KEC	AGC, Squelch Control
IC3	TDA2003	ST	AF Power Amplifier
IC4	LC7152NM	SANYO	PLL
IC5	KIA4558F	KEC	FM TX AF
IC8	CMX138	CML	Tone.IC
IC10	4094B	Rohm	Shift,Resistor
IC11	KIA2576	KEC	Switching,Power-Supply
IC12	H8/38124	Renesas	CPU
IC13	AT24C16	ATMEL	EEPROM
IC14	KIA324	KEC	Auto-SQ,Amp(DSS)

3-3. Manufacture Information

●	KEC	-----	KEC Co., LTD.
●	SANYO	-----	SANYO Semiconductor Co., LTD.
●	TOKO	-----	TOKO, Inc.
●	TOSHIBA	-----	Toshiba Semiconductor. Co., LTD.
●	ATMEL	-----	ATMEL Co., LTD
*	NEC	-----	NEC Semiconductor
*	AUK	-----	AUK Semiconductor
*	Rohm	-----	Rohm Co.,Ltd
*	Renesas	-----	Renesas Tech Nology Corp.

4. Description of Frequency Determining and Stabilizing Circuit

4-1. Introduction

The Frequencies for transmitter and receiver first local frequencies are all derived from a signal 4.5MHz crystal by means of a phase locked loop(PLL). The first local oscillator frequencies are 37.660MHz(CH1) to 38.10MHz(CH40). The second local frequency is fixed at 10.240MHz to generate second IF 455KHz. Transmit, the VCO of the PLL operates 26.965MHz(CH1) to 27.405MHz(40CH). The VCO frequency goes to the Buffer Amp circuit Q134, L701.

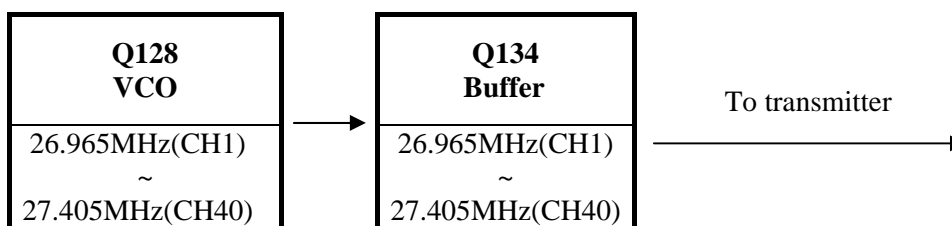

The VCO operating frequency for the receiver is 37.66MHz(CH1) to 38.10MHz(CH40) as the first local oscillator, injected through the buffer amplifier Q129 into the first FET balanced mixer Q102, Q103.

4-2. Basic Synthesis Scheme

The crystal frequency(4.5MHz) is divided by 1800 times to make 2.5KHz which is fed to one side of the phase detector. The VCO output is divided by a programmable divider, and fed to other side of the phase detector Pin 9, 10 of IC4. Passing the phase detector output closes the feedback loop through an active low pass filter and using the output to control the VCO frequency through varicap diode D112. Under locked conditions, both of phase detector input signal must be identical at 2.5KHz.

The VCO frequency is then given by ;

Receiver : $F_{vco} / N = 0.005$ [MHz] OR $F_{vco} = 0.005 \times N$ [MHz]
 Transmitter : $F_{vco} / N = 0.005$ [MHz] OR $F_{vco} = 0.005 \times N$ [MHz]

Since “N” is an integer, the VCO frequency can be stepped up with in receiver mode 5KHz and transmitter mode 5KHz increments. By suitable choice of “N” the desired output frequency can be obtained.

	Channel 1		Channel 40	
	N	Fvco	N	Fvco
Transmit	5393	26.965	5481	27.405
Receiver	7532	37.660	7620	38.100

The VCO frequency goes to the Buffer Amp circuit,

	VCO Output Frequency	Buffer Output Frequency
--	----------------------	-------------------------

Transmit	CH 1 , 26.965 MHz	26.965 MHz

Transmit	CH 40 , 27.405 MHz	27.405 MHz

Since all frequencies are obtained from the crystal controlled PLL oscillator, all outputs are coherent with the crystal oscillator frequency and matching the sample percentage accuracy.

Note that the reference frequency of 5KHz, receiver and transmitter is obtained by dividing the 4.5MHz by 900 times and 1800 times

4-3. Descriptions of Each Block

4-3-1. Introduction

The synthesizer is implemented with the following components;

PLL IC (IC4)
X-TAL (X102)
VCO, VARICAP DIODE (D112)

IC4 is CMOS LSI that includes most of PLL block.

The Q128, L301, C232, C242, C243, C244, varicap diode D112 are clap oscillator circuit to operate as a VCO of the IC4. Q127 is a switching transistor to connect or disconnect the tuning capacitor in the VCO oscillator tank circuit for transmitter or receiver.

Q129 works as a buffer amplifier for RX local frequencies (37MHz) and TX carrier generating frequencies(26MHz)

4-3-2. Reference Frequency

The crystal X102(4.5MHz) and other components at Pin 1 and 24 of IC4 can make a reference frequency oscillator with internal amplifier.

4-3-3. VCO

Q128 and surrounding parts are consisting a clap oscillator works as a VCO of IC4. With appropriate control voltage on D112 the VCO can be oscillate over the required range of 26.965MHz to 38.10MHz.

4-3-4. Programmable Divider and Its Control

The programmable input for each channel are steted by the PLL Clock(Pin 56), PLL Data(Pin 55), PLL Enable(Pin 58) of IC12. Each input signal to control the PLL ic is done with provide key input Pin 73, 74, 75. For each key input, an internal code converts EEPROM appropriate control to the programmable divider for that channel.

Since the change transmit and receive, and additional bit is required at Pin 66 of IC12 to allow the ROM to recognize the status TX or RX.

During transmit the push to talk switch makes Pin 66 ground, PLL IC works under transmit status.

The programmable divider output fed to the phase detector for compare with the 5KHz reference frequency IC4. See table 1 for actual input and divide ratio on all channels.

4-3-5. Phase Detector and VCO Control

The phase detector is a digital phase comparator witch compares the phase of the reference signal with programmable divider output square waves and develops a series of pulses whose dc level depends on the phase error of each signal.

The phase detector pulse output is fed to an active low pass filter and RC low pass filter output signal of IC4 is filtered and fed to varicap D112 control the VCO frequency.

4-3-6. Transmitter / Receiver Buffer AMP

Output signal of Q128 is fed into the buffer amplifier Q129, L3 to generate TX carrier frequency and 1'st local frequencies.

4-3-7. Transmitter Buffer

The output signal of Q129, L3 goes to an amplifier with tuning circuit Q134, L701, which buffer incoming 26MHz signals.

4-3-8. Switching of Turning Capacitor in VCO

The VCO circuit must tune with a wide range of frequencies 26.965MHz ~ 27.405MHz for transmitter and 37.66MHz ~38.10MHz for receiver.

To comply above range of VCO, the tuning capacitance should switch for transmission. The tuning circuit consists with L301, C232, C242, C243, and C244. When the VCO is working as a receiver Q127 becomes turn OFF. So, L301 and C232, D112 makes turning function.

When transmitting, Q127 becomes ON. So, L301 and a parallel capacitance of C232 and C241 make turning function.

4-3-9. Receiver Local Oscillator Outputs

- FIRST MIXER :

The secondary output signal of L107 is injected to the sources of 1st mixer Q102, Q103 in the 1st IF mixer section.

- SECOND MIXER :

The output of 10.24MHz oscillator circuit with X101 is injected into the IF IC(IC1) internally. Incoming IF signal and 10.24MHz signal are mixed inside the IF IC to extract 2nd IF signal 455KHz.

FM audio Signals are recovered with the way of quadrature detector.

AM signals are recovered with envelope detector.

4-4. Frequency Stability

Let : F_o = Crystal oscillator frequency
 F_r = Phase detector reference frequency
 F_{vco} = VCO frequency
 F_t = Transmit frequency

Then : Receiver : $F_r = F_o/900$
 Transmitter : $F_r = F_o/900$

And under locked conditions : $F_r = F_{vco} / N$

Where, "N" is the programmable divider divide ratio.

Then : $F_{vco} = N \times F_r$

From which it can be seen, the percentage error in F_t is the same as the percentage error in F_o . The stability of the crystal oscillator is determined primarily by the crystal itself and having lesser deviation by the active and passive components of the oscillator. The choice of crystal and components is such that the required frequency stability is maintained over the required voltage and temperature range.

4-5. Description of other Circuits

4-5-1. Transmitter

A. RF Amplification

RF carrier frequencies are obtained at the output of buffer amplifier Q134 and turning IFT coil L701, The input of VCO frequencies 26MHz is selected at the buffer output, The output of buffer amplifier Q134 is fed through turning IFT coil L701, L703 to the base of pre driver amplifier Q135. It's output; 27MHz is coupled to RF driver amplifier Q136, a low-level class C power amplifier. Driver Q136 supplies the necessary power gain to operate RF final Q138 at the maximum efficient. The output of Q138 is supplied to the antenna through L-C turning circuit.

B. Circuit for Suppression of Spurious Radiation

The turning circuit between the output of final amplifier Q138 and antenna, 4-stage “ ” network C322, C323, C324, L711, C325, C326, L712, C328, C329, L713, C331, C332, C333, L714, C334 serves as a spurious radiation suppressor. This network also servers to match the impedance between TX power amplifier Q138 and the antenna.

C. Circuits for Limiting Power

After finished all alignment, the constant voltage supply circuit limits the available power 4W or slightly less. RV106 and corresponding three-transistor control supply voltage of RF power amplifier. When power low switch function Q145 changed the supply voltage. Tune all the trimming parts for maximum indication of RF power meter and adjust RV104 to make 4W indication of RF power meter. After finishing the above adjustments check the RF power meter reading is changed 1W under “LOW” state.

The turning is adjustment so that the actual power is from 3.8W to 4.0W. There are no other additional controls for adjusting the TX output power.

D. Modulation Control

Modulation of the RF is a process that begins with the audio picked up by the microphone.

<FM>

The microphone input is fed to mic audio amplifier IC5 that drives modulation vricap diode D113 in the VCO circuit RV107 limits the incoming modulation audio levels to inhibit over modulation. While reading the modulation factor on the modulation analyzing equipment, adjustment RV107 shall not exceed 2.0KHz deviation.

<AM>

Modulation signals are filtered with RC network and goes to the audio power amplifier IC3 in to make normal signal level to achieve wanted modulation. IC3 drives T101, which is a combination AF output/modulation transformer. During transmit, one of the secondary windings of T101 is tied between the 13.2V DC supply and the collectors of RF driver Q136 and RF power amplifier Q138. As the audio passes through T101 it causes the collector supplies of Q136 and Q138 to vary with audio, producing an AM signal at carrier frequency.

To avoid over modulation of the carrier, a protection of the modulating signal is fed back from the T101 through the AMC circuit, Q119 and Q120, to control the gain of IC3 and sets the maximum level of modulation. Form the center tab of RV102 and Q120 the feedback signal is rectified by diode D109, filtered by C202, and supplied the Q119. The collector of Q119 is tied directly TX audio input to control gain. That is, when the audio output is higher than the preset level of RV102, the information is reflected through Q119 and Q120, reducing the gain of IC3

4-5-2. Receiver

Overload protection is provided to receiver's semiconductors by diode D101. These diodes have a little effect on the incoming signal from another CB station; they protect the receiver from stray transmitter energy.

In the receiver mode of operation, Q142 transistor is turned on. Also bias voltage is applied to Q101, Q102, Q103, IC1.

Q101 is a 27MHz RF input amplifier, and any excessive input signal is limited by diode D101.

CB receiver is dual conversion super-heterodyne type with the first IF 10.695MHz and the second IF 455KHz.

Receiver is separated to blocks, 1'st IF section and 2'nd IF section. The PLL synthesizer supplies 1'st local frequency 37.660MHz ~ 38.10MHz. The amplified 27MHz is mixed. With the provide 1'st local frequencies Q102, Q103 mixes the incoming RF signal to generate 1'st IF signal. The resulting first IF is 10.695MHz. Q102 and Q103 is the first converter, and 10.695MHz is sharply filtered by L108 and crystal filter XF101. The first IF is again mixed with a second local oscillator of 10.24MHz.

With the 10.240MHz signal, IC1 FM IF IC converts the incoming signals to generate 2'nd IF signal and recovered audio signals. 2'nd IF is filtered by a razor sharp ceramic filter CF101 coupled. The 455KHz signal from the 2'nd IF filter was amplified and limits internally. After amplification the signals fed to the quadrature detector loop L109. Then could see the recovered signals Pin 8 of IC1.

With the amplitude of recovered signals, Q111 serves as an amplifier.

AM signals from the Pin 5 of IC1 were tapped with C135 and amplified two-stage amplifier Q114, Q115. Q114 is a first 455KHz amplifier, and the Q114 being the last amplifier. D107 is a detector diode witch produce audio signal as well as negative DC voltage for AGC action. The negative voltage also provides forward biasing to the emitter of ANL clipping transistor Q116. The biasing voltage has a time constant determined R162 and C168. Therefore any sharp negative going pulse from D107 will back bias Q116 and clipped. The way to recover the AM information audio is envelope detector.

5. Test Equipment Setup and Test Procedure with Alignment Instructions

5-1 General Section

5-1-1 Test Equipment Required

- DC power supply(13.8V/3A)
- DC Voltmeter or Oscilloscope
- RF attenuator (30dB)

5-1-2 Test Procedure and Alignment

Step	Setting	Connection	Adjuster	Adjust for
1	RX VCO voltage Adj. Channel & Frequency : 1CH, 26.956 MHz Mic : Receive Volume : Optional Squelch : Optional	DC voltmeter to VCO Test point (Figure 1)	L301	1.9~2.1 V DC
2	TX VCO voltage Adj. Channel & Frequency : 1CH, 26.956 MHz Mic : Transmit(No Mod) Volume : Optional Squelch : Optional	DC voltmeter to VCO Test point (Figure 1)	L301	4.8~5.0 V DC

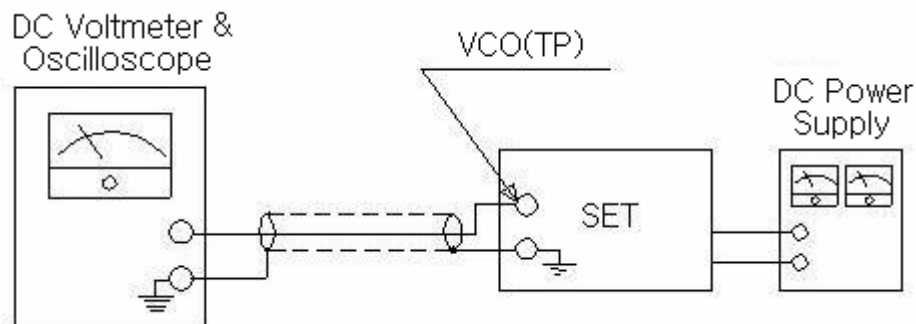

Figure 1

5-2 Transmitter Section

5-2-1 Test Equipment Required

- RF Power Meter
- 50 ohms load (non-inductive)
- RF attenuator (30dB)
- Oscilloscope
- Audio generator
- DC power supply(13.8V/3A)
- Spectrum analyzer
- Frequency counter
- Coupler
- Modulation meter

5-2-2 Test Procedure and Alignment

Step	Setting	Connection	Adjuster	Adjust for
1	RF Power Adj. Channel : 19CH Function : AM or FM Mode MIC : Transmit Volume : Optional Squelch : Optional	Connect dummy load and RF Power Meter to the EXT-ANT connector on the set(Figure 3)	L701 L703	Maximum indication on the Power Meter(4.0W). If indication is not in 4W range, ACP Adjustment(RV104)
2	Frequency Adj. Channel & Frequency : 19CH, 27.185 MHz Function : AM or FM Mode Mic : Transmit(No Mod) Volume : Optional Squelch : Optional	Connect dummy load and Frequency Counter through Coupler to RF Power Meter. Connect RF Power Meter to EXT-ANT connector on the set(Figure 2).	CT1	Be sure that the indication of the transmitter frequency is 27.185MHz \pm 300 Hz on the Frequency Counter
3	AM Modulation Adj. Channel & Frequency : 19CH, 27.185MHz MIC: Transmit Function : AM Mode Volume : Optional Squelch : Optional	Connection the audio generator (set to 1 KHz)to the microphone. Connect the modulation meter through the RF attenuator to the ANT Connector. Adjust the audio signal level to obtain by 50% modulation. When you increase the audio signal by 20 dB, the modulation should not exceed 90% Modulation(Figure 3).	RV102	80% ~ 90%

<p>4</p>	<p>FM Deviation Adj. Channel & Frequency : 19CH, 27.185MHz MIC : Transmit Function : FM Mode Volume : Optional Squelch : Optional</p>	<p>Connection the audio generator (set to 1 KHz)to the microphone. Connect the modulation meter through the RF attenuator to the ANT Connector. Adjust the audio signal level to obtain by 1KHz deviation. When you increase the audio signal by 20 dB, the deviation should not exceed 2.0KHz deviation(Figure 3).</p>	<p>RV107</p>	<p>1.8KHz ~ 2.0KHz</p>

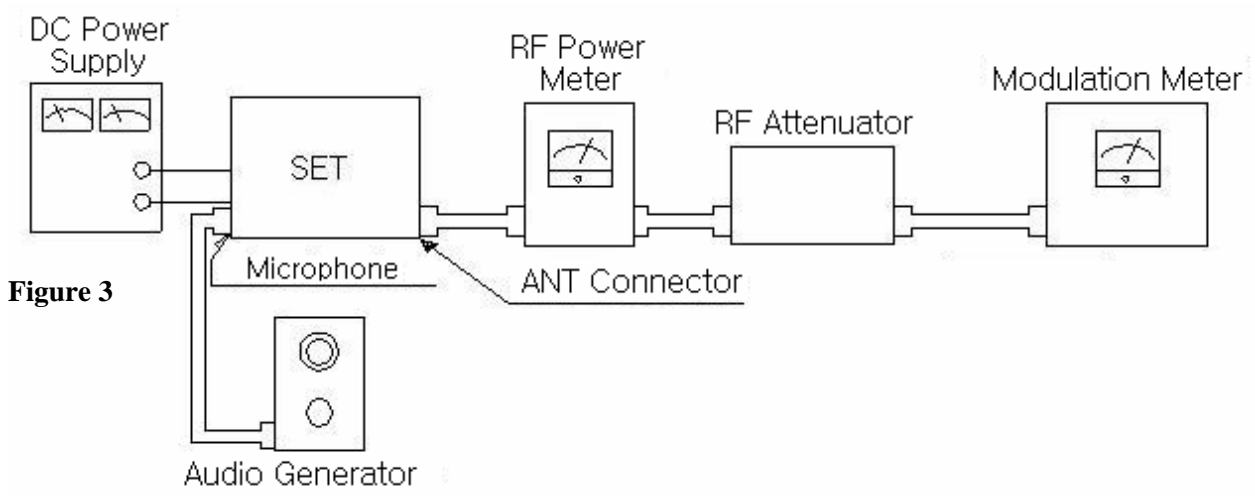
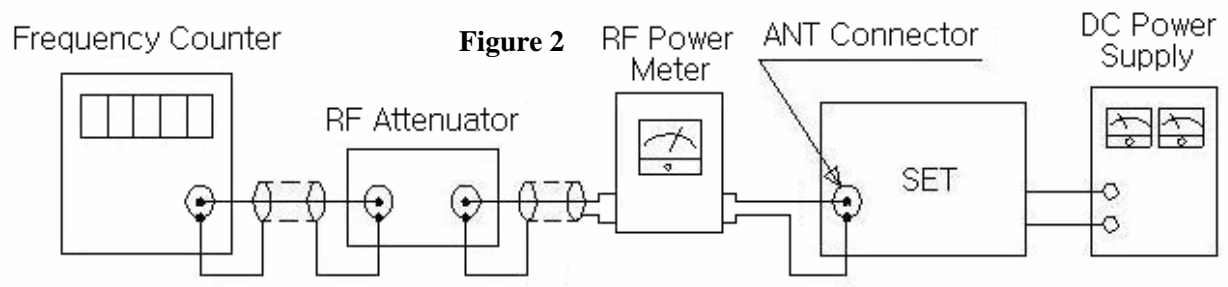

5-3 Receiver Section

5-3-1 Test Equipment Required

- Standard Signal Generator(SSG)
- DC power supply(13.8V/3A)
- AC Level Meter
- Distortion Meter
- Oscilloscope
- SINAD Meter
- 8 ohm Dummy Load

5-3-2 Test Procedure with Alignment

Step	Setting	Connection	Adjuster	Adjust for
1	AM Audio Output Adj. Channel & Frequency : 19CH, 27.185MHz MIC : Receive Function : AM Mode Volume : Full clockwise Squelch : Turn to counter clockwise	Connect RF Signal Generator to EXT-ANT Connector. Connect AC Level Meter and Distortion Meter and SINAD Meter across EXT SPK jack with 8 ohm Dummy Load(Figure 4)	L101 L103 L104 L105 L107 L108 L110	Maximum indication on AC Level Meter. Reduce output from SSG until the audio output becomes about 2V.
2	FM Audio Output Adj. Channel & Frequency : 19CH, 27.185MHz MIC : Receive Function : FM Mode Volume : Full clockwise Squelch : Turn to counter clockwise	Connect RF Signal Generator to EXT-ANT Connector. Connect AC Level Meter and Distortion Meter and SINAD Meter across EXT SPK jack with 8 ohm Dummy Load(Figure 4)	L109	Maximum indication on AC Level Meter. Reduce output from SSG until the audio output becomes about 2V.
3	Squelch Adj. Channel & Frequency : 19CH, 27.185MHz MIC : Receive Function : FM Mode SSG : 27.185MHz, 1KHz, 100uV, 1.2KHz Dev. Volume : Full clockwise Squelch : Full clockwise clockwise	Connect RF Signal Generator to EXT-ANT Connector. Connect AC Level Meter and Distortion Meter and SINAD Meter across EXT SPK jack with 8 ohm Dummy Load(Figure 5)	RV101	Adjust until the audio output appears.

--	--	--	--	--

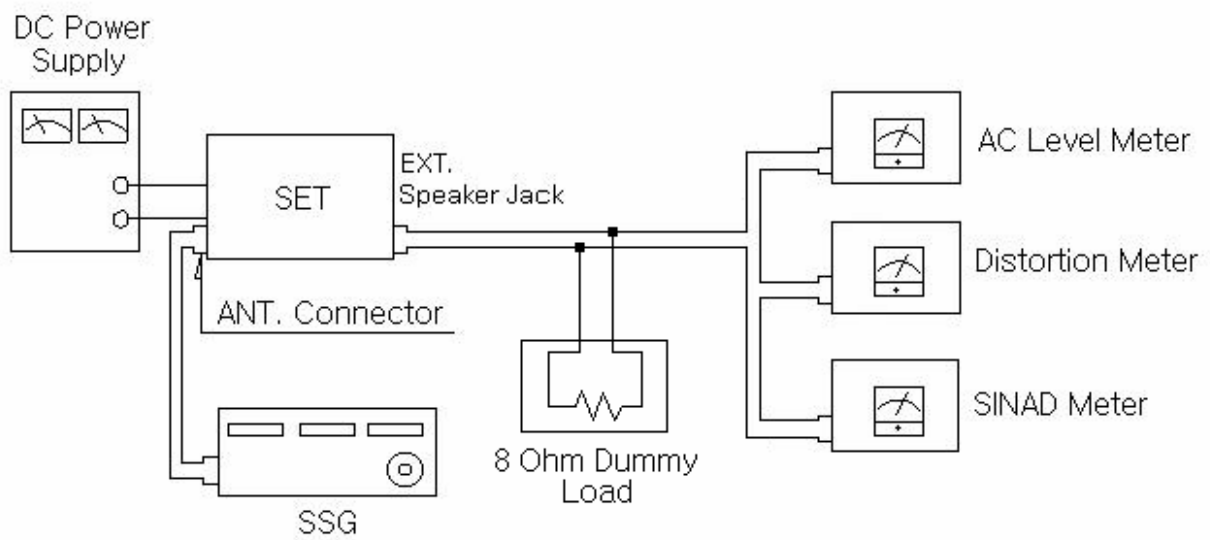

SECTION 3. PART LIST

NO	PART NUMBER	DESCRIPTION	QTY	VENDOR	LOCATION NO.
1	5A0-1100-000	MAIN PCB ASS'Y - TCB1100	1.00		
2	112-100J-S00	METAL OXID RESISTOR 100HM 2W +-5 ST	1.00		R181
3	142-000J-000	CHIP RES. 0603 00HM +-5 PHILIPS	2.00		R139A R119
4	142-100J-000	CHIP RES. 0603 100HM +-5 PHILIPS	1.00		R222
5	142-101J-000	CHIP RES. 0603 1000HM +-5 PHILIPS	10.00		R104 R107 R143 R158 R159 R243 R305 R310 R179 R443
6	142-102J-000	CHIP RES. 0603 1KOHM +-5 PHILIPS	16.00		R121 R154 R170 R182 R202 R204 R205 R225 R226 R234 R236 R242 R313 R354 R434
7	142-103J-000	CHIP RES. 0603 10KOHM +-5 PHILIPS	25.00		R29 R42 R43 R114 R120 R133 R184 R194 R223 R237 R245 R248 R303 R402 R412 R416 R422 R423 R424 R426 R428 R429 R432 R435 R445
8	142-104J-000	CHIP RES. 0603 100KOHM +-5 PHILIPS	15.00		R100 R110 R122 R135 R141 R145 R169 R192 R241 R400 R411 R427 R430 R436 R438 R441
9	142-105J-000	CHIP RES. 0603 1MOHM +-5 PHILIPS	3.00		R186 R198 R408
10	142-123J-000	CHIP RES. 0603 12KOHM +-5 PHILIPS	1.00		R418
11	142-152J-000	CHIP RES. 0603 1.5KOHM +-5 PHILIPS	3.00		R125 R306 R352
12	142-153J-000	CHIP RES. 0603 15KOHM +-5 PHILIPS	3.00		R118 R156 R224
13	142-154J-000	CHIP RES. 0603 150KOHM +-5 PHILIPS	2.00		R185 R301
14	142-184J-000	CHIP RES. 0603 180KOHM +-5 PHILIPS	4.00		R405 R437 R439 R442
15	142-220J-000	CHIP RES. 0603 220HM +-5 PHILIPS	1.00		R425
16	142-221J-000	CHIP RES. 0603 2200HM +-5 PHILIPS	3.00		R105 R106 R302
17	142-222J-000	CHIP RES. 0603 2.2KOHM +-5 PHILIPS	9.00		R171 R173 R206 R246 R249 R351 R356 R404 R453
18	142-223J-000	CHIP RES. 0603 22KOHM +-5 PHILIPS	14.00		R112 R131 R152 R153 R172 R201 R227 R229 R232 R247 R250 R300 R312 R406 R446 R447
19	142-224J-000	CHIP RES. 0603 220KOHM +-5 PHILIPS	4.00		R165 R199 R200 R395
20	142-225J-000	CHIP RES. 0603 2.2MOHM +-5 PHILIPS	2.00		R116 R363
21	142-229J-000	CHIP RES. 0603 2.20HM +-5 PHILIPS	3.00		R175 R177 R178
22	142-272J-000	CHIP RES. 0603 2.7KOHM +-5 PHILIPS	1.00		R157
23	142-273J-000	CHIP RES. 0603 27KOHM +-5 PHILIPS	2.00		R102 R407
24	142-302J-000	CHIP RES. 0603 3KOHM +-5 PHILIPS	2.00		R307 R308
25	142-333J-000	CHIP RES. 0603 33KOHM +-5 PHILIPS	2.00		R164 R417
26	142-334J-000	CHIP RES. 0603 330KOHM +-5 SAMSUNG_PHILIPS	1.00		R413
27	142-335J-000	CHIP RES. 0603 3.3MOHM +-5 PHILIPS	1.00		R139
28	142-391J-000	CHIP RES. 0603 3900HM +-5 PHILIPS	1.00		R362
29	142-470J-000	CHIP RES. 0603 470HM +-5 PHILIPS	4.00		R132 R183 R309 R311
30	142-471J-000	CHIP RES. 0603 4700HM +-5 PHILIPS	4.00		R101 R108 R109 R134 R155 R203 R415
31	142-472J-000	CHIP RES. 0603 4.7KOHM +-5 PHILIPS	10.00		R111 R126 R176 R208 R304 R365 R401 R403 R433
32	142-473J-000	CHIP RES. 0603 47KOHM +-5 PHILIPS	14.00		R144 R151 R161 R162 R163 R193 R195 R196 R197 R221 R231 R409 R419 R421
33	142-474J-000	CHIP RES. 0603 470KOHM +-5 PHILIPS	6.00		R117 R142 R188 R189 R314 R364
34	142-563J-000	CHIP RES. 0603 56KOHM +-5 PHILIPS	5.00		R103 R136 R233 R235 R239
35	142-682J-000	CHIP RES. 0603 6.8KOHM +-5 PHILIPS	1.00		R115
36	142-683J-000	CHIP RES. 0603 68KOHM +-5 PHILIPS	1.00		R137
37	142-823J-000	CHIP RES. 0603 82KOHM +-5 PHILIPS	1.00		R166
38	142-824J-000	CHIP RES. 0603 820KOHM +-5 PHILIPS	2.00		R397 R414
39	162-102V-000	TRIM. POTENTIOMETER WS0612-B102-000-G36 CTR	1.00	CTR	RV106
40	162-103V-000	TRIM. POTENTIOMETER WS0612-B103-000-G36 CTR	1.00	CTR	RV101
41	162-104V-001	TRIM. POTENTIOMETER WS0612-B104-000-G36 CTR	3.00	CTR	RV100 RV103 RV104
42	162-222V-001	TRIM. POTENTIOMETER WS0612-B222-000-G36 CTR	1.00	CTR	RV102
43	162-223V-001	TRIM. POTENTIOMETER WS0612-B223-000-G36 CTR	1.00	CTR	RV107
44	172-102J-000	NTC THERMISTOR 0603 1KOHM 18XQ102JOSRB MURATA	1.00	MURATA	TH1
45	172-103J-800	NTC THERMISTOR 10KOHM NCP18XH103J03RB MURATA	1.00	MURATA	TH2A
46	201-2272-M00	ELECT CAP. 220UF 10V 5x10 KOSHIN	1.00	KOSHIN	C425
47	202-1059-M00	ELECT CAP. 1UF KR1-16V010MA 5x11 DONGXIANG	1.00	DONGXIANG	C168
48	202-1065-M00	ELECT CAP. 10UF 16V 4x7 +-20	6.00		C147 C182 C203 C354 C372
49	202-1070-M01	ELECT CAP. 100UF 16V 5x11 KOSHIN	9.00	KOSHIN	C120 C137 C250 C300 C352 C357 C377 C401 C432
50	202-1080-M00	ELECT CAP. 1000UF 16V 8x16 KOSHIN	5.00	KOSHIN	C181 C184 C185 C359 C362
51	202-2249-M00	ELECT CAP. 0.22UF KR1-16VR22MA 5x11 DONGXIANG	1.00	DONGXIANG	C138
52	202-4759-M00	ELECT CAP. 4.7UF KR1-16V4R7MA 5x11 DONGXIANG	1.00	DONGXIANG	C255
53	202-4769-M00	ELECT CAP. 47UF KR1-16V470MA 5x11 DONGXIANG	4.00	DONGXIANG	C153 C202 C355 C415

54	204-4770-M00	ELECT CAP. 470UF 35V 10x16	1.00		C363
55	212-010C-6C0	CHIP CERAMIC CAP. 0603 1PF NP0 50V +-0.25 PHILIPS	1.00		C341
56	212-030C-6C0	CHIP CERAMIC CAP. 0603 3PF NP0 50V +-0.25 PHILIPS	1.00		C251
57	212-050C-6C0	CHIP CERAMIC CAP. 0603 5PF NP0 50V +-0.25 PHILIPS	1.00		C127
58	212-080C-6C0	CHIP CERAMIC CAP. 0603 8PF NP0 50V +-0.25 PHILIPS	1.00		C247
59	212-101C-6J0	CHIP CERAMIC CAP. 0603 100PF NP0 50V +-5 PHILIPS	9.00		C103 C115 C223 C224 C225 C243 C244 C307 C329
60	212-102B-3K0	CHIP CERAMIC CAP.0603 0.001UF X7R 16V +-10 PHILIPS	8.00		C102 C179 C186 C205 C229 C404 C428 C430
61	212-103B-3K0	CHIP CERAMIC CAP. 0603 0.01UF X7R 16V +-10 PHILIPS	32.00		C116 C121 C123 C124 C125 C126 C129 C135 C143 C152 C163 C171 C204 C234 C239 C245 C301 C302 C306 C351 C353 C356 C358 C364 C416 C417 C422
62	212-104B-3K0	CHIP CERAMIC CAP.0603 0.1UF X7R 16V +-10 PHILIPS	36.00		C110 C130 C133 C134 C136 C139 C142 C144 C151 C154 C155 C156 C162 C169 C206 C231 C235 C240 C248 C252 C342 C343 C402 C405 C407 C408 C410 C411 C412 C413 C414 C421 C424 C426 C427 C433
63	212-105F-3Z0	CHIP CERAMIC CAP. 0603 1UF Y5V 16V -20+80 PHILIPS	5.00		C119 C157 C161 C201 C237
64	212-121C-6J0	CHIP CERAMIC CAP. 0603 120PF NP0 50V +-5 PHILIPS	1.00		C318
65	212-151C-6J0	CHIP CERAMIC CAP. 0603 150PF NP0 50V +-5 PHILIPS	5.00		C104 C107 C111 C232 C322
66	212-180C-6J0	CHIP CERAMIC CAP. 0603 18PF NP0 50V +-5 PHILIPS	4.00		C108 C112 C128 C236
67	212-181C-6J0	CHIP CERAMIC CAP. 0603 180PF NP0 50V +-5 PHILIPS	2.00		C254 C333
68	212-220C-6J0	CHIP CERAMIC CAP. 0603 22PF NP0 50V +-5 PHILIPS	2.00		C222 C242
69	212-221C-6J0	CHIP CERAMIC CAP. 0603 220PF NP0 50V +-5 PHILIPS	4.00		C249 C309 C319 C332
70	212-223B-3K0	CHIP CERAMIC CAP. 0603 0.022UF X7R 16V +-10 PHILIP	5.00		C146 C167 C173 C178 C403
71	212-224B-3K0	CHIP CERAMIC CAP. 0603 0.22UF X7R 16V +-10 PHILIPS	4.00		C170 C175 C376 C379
72	212-273B-3K0	CHIP CERAMIC CAP.0603 0.027UF X7R 16V +-10 PHILIP	1.00		C439
73	212-331C-6J0	CHIP CERAMIC CAP. 0603 330PF NP0 50V +-5 PHILIPS	4.00		C314 C315 C328 C373
74	212-390C-6J0	CHIP CERAMIC CAP. 0603 39PF NP0 50V +-5 PHILIPS	2.00		C114 C241
75	212-391C-6J0	CHIP CERAMIC CAP. 0603 390PF NP0 50V +-5 PHILIPS	3.00		C323 C325 C326
76	212-470C-6J0	CHIP CERAMIC CAP. 0603 47PF NP0 50V +-5 PHILIPS	8.00		C101 C106 C109 C113 C132 C246 C253 C305
77	212-471C-6J0	CHIP CERAMIC CAP. 0603 470PF NP0 50V +-5 PHILIPS	4.00		C100 C118 C313 C371
78	212-473B-3K0	CHIP CERAMIC CAP. 0603 0.047UF X7R 16V +-10 PHILIP	9.00		C141 C164 C165 C166 C226 C310 C311 C312 C321
79	212-474B-3K0	CHIP CERAMIC CAP. 0603 0.47UF X7R 16V +-10 PHILIPS	1.00		C183
80	212-560C-6J0	CHIP CERAMIC CAP. 0603 56PF NP0 50V +-5 PHILIPS	1.00		C131
81	212-680C-6J0	CHIP CERAMIC CAP. 0603 68PF NP0 50V +-5 PHILIPS	1.00		C105
82	212-681C-6J0	CHIP CERAMIC CAP. 0603 680PF NP0 50V +-5 PHILIPS	1.00		C419
83	212-683B-6K0	CHIP CERAMIC CAP. 0603 0.068UF X7R 16V +-10 PHILIP	1.00		C418
84	212-820C-6J0	CHIP CERAMIC CAP. 0603 82PF NP0 50V +-5 PHILIPS	5.00		C304 C327 C331 C406 C409
85	212-821C-6J0	CHIP CERAMIC CAP. 0603 820PF NP0 50V +-5 PHILIPS	1.00		C420
86	221-2243-M00	CHIP TANTAL CAP. 0.22UF 10V A SIZE +-20	1.00		C434
87	221-2254-M00	CHIP TANTAL CAP. 2.2UF 16V A SIZE +-20	1.00		C227
88	22D-101C-J00	DISK CAP. CC1HCH101J(100PF) 50V +-5	1.00	SAMIL	C334
89	22D-470C-J00	DISK CAP. 47PF 50V +-5	1.00		C335
90	230-2000-000	DIP TRIMMER CAP. 6DIA 20PF KCVN620 FOKITS	1.00	FOKITS	CT1
91	300-0211-000	CHIP TR. KTK211GR KEC	2.00	KEC	Q102 Q103
92	300-1504-000	CHIP TR KTA1504S SOT-23 KEC	2.00	KEC	Q116 Q120
93	300-1505-100	CHIP TR. SWITCHING (SOT-23) KTA1505S-Y KEC	1.00	KEC	Q141
94	300-3875-000	CHIP TR. SWITCHING KTC3875S SOT-23 KEC	7.00	KEC	Q107 Q108 Q109 Q111 Q119 Q142 Q144
95	300-3880-000	CHIP TR KTC3880S SOT-23 KEC	6.00	KEC	Q114 Q115 Q129 Q130 Q134 Q135
96	301-4226-000	CHIP TR RF 2SC4226 R24 NEC	2.00	NEC	Q101 Q128
97	302-1241-000	TRANSISTOR KTA1241 KEC	1.00	KEC	Q121
98	302-2314-000	TR 2SC2314F SANYO	1.00	SANYO	Q136
99	302-3205-000	TR. DIP TYPE KTC3205 KEC	1.00	KEC	Q143
100	305-0101-000	CHIP TR KRC101S SOT-23 KEC	6.00	KEC	Q113 Q122 Q125 Q127 Q152 Q154
101	305-0102-000	CHIP TR KRC102S SOT-23 KEC	1.00	KEC	Q145
102	305-0110-000	CHIP TR KRC110S SOT-23 KEC	1.00	KEC	Q131
103	305-0111-000	CHIP TR KRC111S SOT-23 KEC	7.00	KEC	Q117 Q118 Q132 Q133 Q146 Q147 Q151
104	305-0112-000	CHIP TR KRC112S SOT-23 KEC	2.00	KEC	Q110 Q112
105	305-9101-000	CHIP TR KRA101S SOT-23 KEC	1.00	KEC	Q153
106	311-1610-000	POWER FET RD16HHF1 MITSUBISHI	1.00	MITSUBIS	Q138
107	331-0324-A02	IC OP AMP KIA324F KEC	2.00	KEC	IC 14 IC5
108	331-0358-A00	IC OP AMP KIA358F KEC	1.00	KEC	IC2
109	332-2003-000	IC AUDIO AMP TDA2003 ST	1.00	ST	IC3
110	333-2576-A00	IC REGULATOR KIA2576FP00(SMD TYPE) KEC	1.00	KEC	IC11
111	335-7152-A00	IC PLL LC7152NM SANYO	1.00	SANYO	IC4
112	336-5019-A00	IC IF SL5019 AUK	1.00	DAYTRONICS	IC1
113	33C-0138-A00	IC CTCSS CMX138 CML	1.00	CML	IC8

114	33C-2576-A00	IC DD CONVERTER KIA2576PI00 KEC	1.00	KEC	IC11
115	33C-4094-A00	IC BU4094BCFV ROHM	1.00		IC10
116	340-0230-A00	DIODE ZENER Z02W3.0V SOT-23 KEC	2.00	KEC	D106 D122
117	340-0256-A00	DIODE ZENER Z02W5.6V SOT-23 KEC	1.00	KEC	D118
118	340-0291-A00	DIODE ZENER Z02W9.1V SOT-23 KEC	1.00	KEC	D119
119	341-0251-A00	DIODE VARICAP KDV251S SOT-23 KEC	4.00	KEC	D100 D102 D112 D113
120	342-0033-A00	SCHOTTKY DIODE SMAB33 KEC	1.00	KEC	D120
121	342-0181-A00	CHIP DIODE SWITCHING KDS181 SOT-23 KEC	1.00	KEC	D117
122	342-0184-A00	CHIP DIODE SWITCHING KDS184 SOT-23 KEC	5.00	KEC	D24 D111 D114 D105 D115
123	342-0226-A00	CHIP DIODE SWITCHING KDS226 SOT-23 KEC	5.00	KEC	D101 D110 D116 D123 D125
124	342-1114-A00	CHIP DIODE SWITCHING KDS114 KEC	1.00	KEC	D104
125	343-1060-000	DIODE 1N60	2.00		D107 D109
126	343-4001-000	DIODE 1N4001 VISHAY	2.00		D108 D121
127	343-5402-000	DIODE 1N5402	1.00		D126
128	360-1024-001	CRYSTAL 10.24MHZ 32PF 30PPM HC-49U YOKETAN	1.00	YOKETAN	X101
129	363-0045-000	CRYSTAL 4.5MHZ, HC-49S R49SDA-004500-FA-12-30-TA	1.00	YOKETAN	X102
130	367-1060-200	CRYSTAL FILTER 10.695MHZ 49T-3L 10L08A DTRON	1.00	DTRON	XF101
131	373-0455-100	CERAMIC FILTER LTM455HTW CQ	1.00	CQ	CF101
132	400-0019-000	TRANSFORMER CHOCK T1 FINE	1.00	FINE	T901
133	400-0028-000	TRANSFORMER EI-28(MOD) T2 FINE	1.00	FINE	T101
134	406-0664-000	TROIDAL COIL 13X100UH 0.6X64T	1.00	FINE	T902
135	406-2508-000	COIL SPRING 2.5X0.8X7T : R 0.11UH FINE	1.00	FINE	L704
136	406-4005-000	COIL SPRING 4X0.5X6T : R FINE	2.00	FINE	L712 L713
137	406-4005-300	COIL SPRING 4X0.5X9T : R FINE	1.00	FINE	L714
138	406-5006-000	COIL SPRING 5X0.6X13.5T : R 0.5UH FINE	1.00	FINE	L707
139	406-6008-000	COIL SPRING 6X0.8X5T : R 0.225UH FINE	1.00	FINE	L711
140	410-0273-000	IFT COIL 27MHZ RX1(Wire Diameter : ϕ 0.1) FINE	1.00	FINE	L101
141	410-0280-000	IFT COIL 28MHZ RX22 FINE	1.00	FINE	L107
142	410-1070-000	IFT COIL 10.7MHZ RX-B RX3 FINE	1.00	FINE	L108
143	410-1650-000	IFT COIL 16.5MHZ VCO VCO1 FINE	1.00	FINE	L301
144	410-1651-000	IFT COIL 16.5MHZ VCO11 FINE	1.00	FINE	L301
145	410-3011-000	IFT COIL TX 30MHZ TX11 FINE	1.00	FINE	L701
146	410-3022-000	IFT COIL TX 30MHZ TX22 FINE	1.00	FINE	L703
147	410-4550-000	IFT COIL DETECTOR 455KHZ RX4 FINE	1.00	FINE	L109
148	410-4551-000	IFT COIL 455KHZ-B RX5 FINE	1.00	FINE	L110
149	425-0150-000	COIL AXIAL 1.5UH AL0305 MATSUTA	2.00	MATSUTA	L102 L106
150	425-1R00-001	COIL AXIAL 1UH AL0305 MATSUTA	1.00	MATSUTA	L3
151	427-0010-000	COIL RF CHOKE 0.6x5.0x23.5TR 10uH	2.00	FINE	L1 L2
152	427-0017-000	CORE SPRING 5.5TX0.45XM5ERX2.3 0.17UH FINE	3.00	FINE	L103 L104 L105
153	427-0600-000	COIL CHOCK 6UH BOBBIN CORE	1.00	FINE	L111
154	500-1100-000	MAIN PCB FR-4(2 LAYER 1.6T)	1.00	LUCKYVIEW	
155	533-519V-000	SWITCH G5V-1 9V RELAY OMRON	2.00	ASUNG	RE1 RE2
156	534-2505-000	SMD JACK SKJS-2513S-B SEKWANG	1.00		J201
157	534-3500-000	SMD JACK JY-3560-01-250 JT	1.00	JT	J202
158	540-0218-000	WAFER 2PIN PH-2A 180C	1.00	FINE	J205
159	540-0618-000	WAFER 6PIN PH-6A 180C	1.00	FINE	J503
160	541-0239-002	CONNECTOR FD-ANT-1 NINGBO	1.00	NINGBO	
161	547-0825-000	WIRE STRIP D0.8 L25MM	1.00		J701
162	702-C1100-70A	TX TOP BRACKET SPT 0.4T	1.00	DESHAN	
163	702-C1100-80A	TX BOTTOM PLATE SPT 0.4T	1.00	DESHAN	
164	702-C1100-90A	TX BOTTOM BRACKET SPT 0.4T	1.00	DESHAN	
165	702-C7700-80A	VCO SHIELD CAN SPT 0.3T DESHAN	1.00	DESHAN	
166	5A0-1100-100	LCD PCB ASS'Y - TCB1100	1.00		
167	142-000J-000	CHIP RES. 0603 0OHM +-5 PHILIPS	1.00		R23
168	142-102J-000	CHIP RES. 0603 1KOHM +-5 PHILIPS	3.00		R39 R40 R45
169	142-103J-000	CHIP RES. 0603 10KOHM +-5 PHILIPS	12.00		R5 R6 R7 R8 R10 R11 R12 R13 R22 R37 R44 R49
170	142-104J-000	CHIP RES. 0603 100KOHM +-5 PHILIPS	4.00		R1 R2 R3 R25
171	142-105J-000	CHIP RES. 0603 1MOHM +-5 PHILIPS	1.00		R47
172	142-123J-000	CHIP RES. 0603 12KOHM +-5 PHILIPS	1.00		R50
173	142-151J-000	CHIP RES. 0603 150OHM +-5 SAMSUNG_PHILIPS	1.00		R32
174	142-223J-000	CHIP RES. 0603 22KOHM +-5 PHILIPS	6.00		R4 R16 R18 R20 R21 R33
175	142-224J-000	CHIP RES. 0603 220KOHM +-5 PHILIPS	1.00		R24
176	142-331J-000	CHIP RES. 0603 330OHM +-5 SAMSUNG_PHILIPS	1.00		R35

177	142-471J-000	CHIP RES. 0603 470OHM +-5 PHILIPS	2.00		R31 R36
178	142-472J-000	CHIP RES. 0603 4.7KOHM +-5 PHILIPS	1.00		R46
179	142-473J-000	CHIP RES. 0603 47KOHM +-5 PHILIPS	7.00		R9 R15 R17 R19 R26 R27 R28
180	142-681J-000	CHIP RES. 0603 680OHM +-5 PHILIPS	1.00		R38
181	142-682J-000	CHIP RES. 0603 6.8KOHM +-5 PHILIPS	1.00		R48
182	142-823J-000	CHIP RES. 0603 82KOHM +-5 PHILIPS	2.00		R30 R34
183	212-100C-6J0	CHIP CERAMIC CAP. 0603 10PF NP0 50V +-5 PHILIPS	1.00		C8
184	212-104B-3K0	CHIP CERAMIC CAP.0603 0.1UF X7R 16V +-10 PHILIPS	7.00		C1 C2 C3 C5 C7 C12 C14
185	212-220C-6J0	CHIP CERAMIC CAP. 0603 22PF NP0 50V +-5 PHILIPS	2.00		C9 C10
186	212-473B-3K0	CHIP CERAMIC CAP. 0603 0.047UF X7R 16V +-10 PHILIP	1.00		C11
187	221-106A-M00	CHIP TANTAL CAP. 10UF 6V A SIZE +-20	2.00		C4 C13
188	300-1505-100	CHIP TR. SWITCHING (SOT-23) KTA1505S-Y KEC	1.00	KEC	Q1
189	305-0101-000	CHIP TR KRC101S SOT-23 KEC	4.00	KEC	Q2 Q3 Q4 Q5
190	305-0404-100	CHIP TR. KRC404 KEC	1.00	KEC	Q8
191	322-3812-000	IC CPU (OTP) HD64F38124WV RENESAS	1.00	KOSHIDA	IC12
192	338-2416-B00	IC EEPROM AT24C16N-10SI-2.7V ATMEL	1.00	ATMEL	IC13
193	340-0230-A00	DIODE ZENER Z02W3.0V SOT-23 KEC	1.00	KEC	D21
194	350-0036-000	LED DUAL(GREEN / AMBER) BL-HJCGK36J-TRB BRT LED	10.00	BRT LED	D1 D2 D3 D4 D5 D6 D7 D8 D9 D10
195	350-0603-000	CHIP LED BLUE AOT-0603P-B01-V BLUEWIZ	10.00		D11 D12 D13 D14 D15 D16 D17 D18 D19 D20
196	352-4971-100	LCD SDM8A4971B SANTECH	1.00	SANTECH	
197	363-3868-000	CRYSTAL 3.6864MHZ HC-49 / S DTRON	1.00	DTRON	X1
198	500-1100-100	LCD PCB FR-4(2 LAYER 1.6T)	1.00	LUCKYVIEW	
199	500-1100-101	LCD BACKLIGHT PCB(L)	1.00	LUCKYVIEW	
200	500-1100-102	LCD BACKLIGHT PCB(R)	1.00	LUCKYVIEW	
201	539-0127-000	B TO B CONNECTOR F127-F-08DSG(SMD) FINE CONNECTOR	1.00	FINE CONNECTOR	CON1
202	564-1109-100	SWITCH TACT KFC-821 GABOU	6.00	GABOU	SW4 SW5 SW6 SW7 SW8 SW9
203	701-C1100-60A	DIFFUSER ACRYL CLEAR	1.00	XINGTAI	
204	702-C1100-20A	LCD BRACKET SPTE 0.4T	1.00	DESHAN	
205	703-C1100-20A	ZEBRA SILICONE 38.2x7.91x1.0T	1.00	ATM	
206	722-C0000-033	WHITE SHEET 64.20x23.20x0.1T	1.00	ATM	
207	5A0-1100-200	VOLUME PCB ASS'Y - TCB1100	1.00		
208	425-6R80-000	IND. AX 03TYPE LAL03TB6R8K(6.8UH) TAIYO YUDEN	1.00		L501 L502 L504 L506
209	500-1100-200	PCB VOLUME FR-4 (2 LAYER 1.0T)	1.00	LUCKYVIEW	
210	540-0607-000	WIRE HARNESS PH-6PIN TO OPEN UL1007 NO.26 L=70mm	1.00		J502
211	541-0166-002	CONNECTOR SOCKET FD-MIC6PIN-F NINGBO	1.00	NINGBO	J501
212	547-0415-000	HEAT SINK TUBE DIA4.0MM X 15MM	6.00		
213	570-0901-001	VR R09710NS-KQ15A6.0-A103-015 CTR	1.00	CTR	VR1
214	5A0-1100-300	SQUELCH PCB ASS'Y - TCB1100	1.00		
215	500-1100-300	PCB SQUELCH FR-4 (2 LAYER 1.0T)	1.00	LUCKYVIEW	
216	570-0902-001	VR R09710N0-KQ15A6.0-3B103-015 CTR	1.00	CTR	VR2
217	5A0-1100-400	CHANNEL PCB ASS'Y - TCB1100	1.00		
218	500-1100-400	PCB CHANNEL FR-4 (2 LAYER 1.0T)	1.00	LUCKYVIEW	
219	560-9017-000	SW ROTARY TP90N17AE20 15SK TOCOS	1.00	TOCOS	SW3
220	700-C110C-400	COVER ASS'Y - TCB1100	1.00		
221	520-4500-000	SPEAKER 45PHI 40HM 4W ACE	1.00	ACE	
222	702-C1100-01A	UPPER COVER SPC 0.8T BLACK UV COATING	1.00	DESHAN	
223	702-C1100-20A	BOTTOM COVER SPC 0.8T BLACK UV COATING	1.00	DESHAN	
224	706-30081-58A	SCREW MACH(+) 3X8L-TAPTITE BLACK BH	8.00	BONSO	FOR UPPER, BOTTOM COVER MOUNTING
225	700-C110E-400	ESCUTCHEON ASSY - TCB1100	1.00		
226	701-C1100-10A	ESCUTCHEON ABS BLACK	1.00	XINGTAI	
227	701-C1100-20A	WINDOW LENS ACRYL CLEAR	1.00	XINGTAI	
228	701-C1100-20A	ILLUMINATOR(VOL) ACRYL, CLEAR	1.00	XINGTAI	
229	701-C1100-40A	ILLUMINATOR(CH) ACRYL, CLEAR	1.00	XINGTAI	
230	701-C1100-50A	ILLUMINATOR(SQ) ACRYL, CLEAR	1.00	XINGTAI	
231	701-C7700-50A	CH KNOB ABS(BLACK COLOR)	1.00	SOLARIUM	
232	701-C88B0-20A	SQ KNOB ABS BLACK SPRAY	2.00	SOLARIUM	CH:1PCS , SQ:1PCS
233	703-C1100-10A	KEYPAD SILICONE, NATURAL PU SOFT COATING	1.00	DAXIN	
234	706-2605S-NEH	SCREW MACH(+) M2.6X5L Ni PLATED FH	4.00	BONSO	FOR MAIN BODY+ESCUTCHEON MOUNTING
235	712-M70NI-001	RING NUT BsM Ni PLATING	3.00	BONSO	
236	715-C417N-008	SPK FELT MESH BLACK Φ41.7x0.12T	1.00	BONSO	
237	719-S000D-039	WINDOW TAPE 2X18X0.15T(3M ONESIDE DOUBLE TAPE)	2.00	ATM	
238	700-C110M-800	MAIN BODY ASSY - TCB1100	1.00		
239	543-1600-000	POWER CORD 2PIN PLUG ASS'Y UL1015#16 CABLE	1.00	BSQ	

240	701-C4100-30A	CORD STOPPER PP BLACK	1.00	BONSO	
241	701-C5500-80A	BUSH NYLON66+GRASS 15%	1.00	SOARIUM	
242	702-C1100-30A	MAIN BODY EGI 1.0T	1.00	DESHAN	
243	702-C1101-10A	HEATSINK ALUMINUM 3.0t	1.00	DESHAN	
244	702-C7701-30A	ANT. TERMINAL SPTE 0.2T	1.00	DESHAN	
245	706-3008T-BBH	SCREW MACH(+) 3X8L-TAPTITE BLACK BH	4.00	BONSO	Main PCB + Main body mounting
246	706-3010S-BBH	SCREW MACH(+) M3X10L BLACK BH	2.00	BONSO	TR MOUNTING
247	706-3010S-NBH	SCREW MACH(+) M3X10L Ni PLATED BH	2.00		
248	708-2608S-NBH	SCREW Mach(+) M2.6x8L Ni plating BH	2.00	ATM	MAIN BODY+LCD PCB MOUNTING
249	711-M30NI-000	NUT M3 Ni PLATED	4.00	BONSO	TR MOUNTING
250	713-M30NI-S01	SPRING WASHER M3	4.00	BONSO	TR MOUNTING
251	723-C4100-011	INSULATION WASHER PAPER Φ3.0 (Red color)	1.00	ATM	
252	8A0-C110-000	PACKING ASS'Y - TCB1100	1.00		
253	543-1600-100	POWER CORD 2PIN RECEPTACLE ASSY AWG16 10A BSQ	1.00	BSQ	
254	701-C5500-90A	STUD BOLT ABS M6X8L BLACK SOLARIUM	2.00	SOLARIUM	
255	702-C1101-00A	BRACKET SPC T=1.6 UV BLACK COATING	1.00	DESHAN	
256	702-C7701-10A	BRACKET MIC SUS304 1.0T	1.00	DESHAN	
257	703-C7700-50A	PACKING RUBBER	2.00	DAXIN	
258	706-3008T-BBH	SCREW MACH(+) 3X8L-TAPTITE BLACK BH	2.00	BONSO	
259	708-5012T-7TH	SCREW TAP(+) 5X12L-1S ZN PLATING TH	3.00	BONSO	
260	714-M30NI-001	STAR WASHER-S M3 NI PLATING B TYPE	2.00	BONSO	
261	714-M50NI-002	STAR WASHER-L M5 NI PLATING B TYPE	3.00	BONSO	
262	801-C110-000	GIFTBOX SW1E 2.0T	1.00		
263	804-C110-001	INNER BOX A SW1E 2.0T, WHITE	1.00		
264	804-C110-002	INNER BOX B SW1E 2.0T, WHITE	1.00		
265	809-C110-000	OUTBOX DW1E 7.0T	0.20		
266	80A-C110-A00	OUTBOX PAD DW1E 7.0T	0.40		
267	817-0520-000	POLYBAG PE 50X200	1.00		
268	817-0810-000	POLYBAG PE 80X100	1.00		
269	817-0832-000	Bracket POLYBAG PE 80x320mm	1.00		
270	817-1090-000	POLYBAG PE 100X900X0.05T	1.00		
271	817-2525-000	RADIO POLYBAG PE 250x250	1.00		
272	820-C110-000	OWNER'S MANUAL	1.00		
273	830-C110-000	Radio NAME LABEL	1.00		
274	831-C110-000	AMC-5020 MIC NAME LABEL PE 22*12mm	1.00		
275	833-C110-000	CODE 39 SERIAL NO. STICKER	2.00		
276	834-0001-000	WARNING LABEL	1.00		
277	834-0002-000	ROHS STICKER - TTI	0.20		
278	834-C770-MC1	MIC LOGO STICKER PE 34.6*6.6*0.3T(REV.01)	1.00		
279	834-CBCH-ST1	CB CHANNEL STICKER COPPER PAPER 100g / 201X140mm	1.00		
280	834-ROTE-R00	ROSTEST MARK STICKER	1.00		
281	837-0001-000	OPP TAPE 50MM TTI LOGO	0.29		
282	838-0001-000	YELLOW STRAP	0.26		
283	83A-0001-000	SILICA GEL 1g	1.00		
284	905-1100-000	MICROPHONE ASS'Y - TCB1100	1.00		
285	100-273J-S00	FILM RES. 27KOHM 0.125W +-5 ST	1.00	ST	R901
286	212-103B-3K0	CHIP CERAMIC CAP. 0603 0.01UF X7R 16V +-10 PHILIPS	1.00		C951
287	511-7700-000	PCB MIC	1.00	RICHO	
288	523-9765-000	MIC CONDENSOR 4.5V 2.2K -44dB +-2dB	1.00		
289	526-0051-001	CURL CORD 5CORD 1SHIELD FINE	1.00	FINE	
290	541-0600-002	MIC CONNECTOR FD-MIC6PIN-M NINGBO	1.00		
291	545-0280-000	LEAD WIRE BLK 3 : 3 65mm AWG28 1571	2.00		
292	545-0281-000	LEAD WIRE RED 3 : 3 65mm AWG28 1571	2.00		
293	545-0283-000	LEAD WIRE YELLOW 2 : 2 10mm AWG28 1571	1.00		
294	562-2210-000	SW PUSH SKPS-2210C	1.00		
295	564-1109-100	SWITCH TACT KFC-821 GABOU	3.00	GABOU	
296	701-C1100-70A	UPPER COVER ABS, BLACK UP / M / DOWN / SILK	1.00	SOARIUM	
297	701-C7701-20A	BOTTOM COVER ABS BLACK	1.00	SOARIUM	
298	701-C7701-10A	DECO ABS SILVER	1.00	SOARIUM	
299	701-C7701-50A	PUSH LEVER ABS BLACK	1.00	SOARIUM	
300	701-C7701-60A	KNOB ABS BLACK	3.00	SOARIUM	
301	701-C7701-70A	HOLDER PC BLACK	1.00	SOARIUM	
302	703-C5500-20A	SHRINKING TUBE BLACK(ID 6.0XOD7.0X6.0L)	1.00	BONSO	

303	703-C7700-30A	SPK HOLDER RUBBER BLACK	1.00	LONGSHENDA	
304	703-C7700-40A	MIC BUSHING RUBBER BLACK	1.00	LONGSHENDA	
305	708-26102-BPH	SCREW TAP(+) 2.6X10L-2S BLACK FH	1.00	JLC	
306	708-26162-BPH	SCREW TAP(+) 2.6X16L-2S BLACK PH	4.00		
307	718-R0000-002	CUSHION SPK20X24X8.0T(1SIDE DOUBLE TAPE)EVA SPONGE	1.00	BONSO	
308	718-R000N-003	MIC SPONGE 30X7X3T (NO TAPE) EVA SPONGE BLACK	1.00	BONSO	
309	723-C7700-002	SHRINGKAGE TUBE D3X50MM BLACK	1.00	BONSO	
310	817-1090-000	POLYBAG PE 100X900X0.05T	1.00		FOR MICROPHONE
311	831-C770-000	NAME LABEL PE 22X12X0.2T	1.00		
312	834-C770-MC1	MIC LOGO STICKER PE 34.6*6.6*0.3T(REV.01)	1.00		

SECTION 4. MECHANICAL DISASSEMBLY

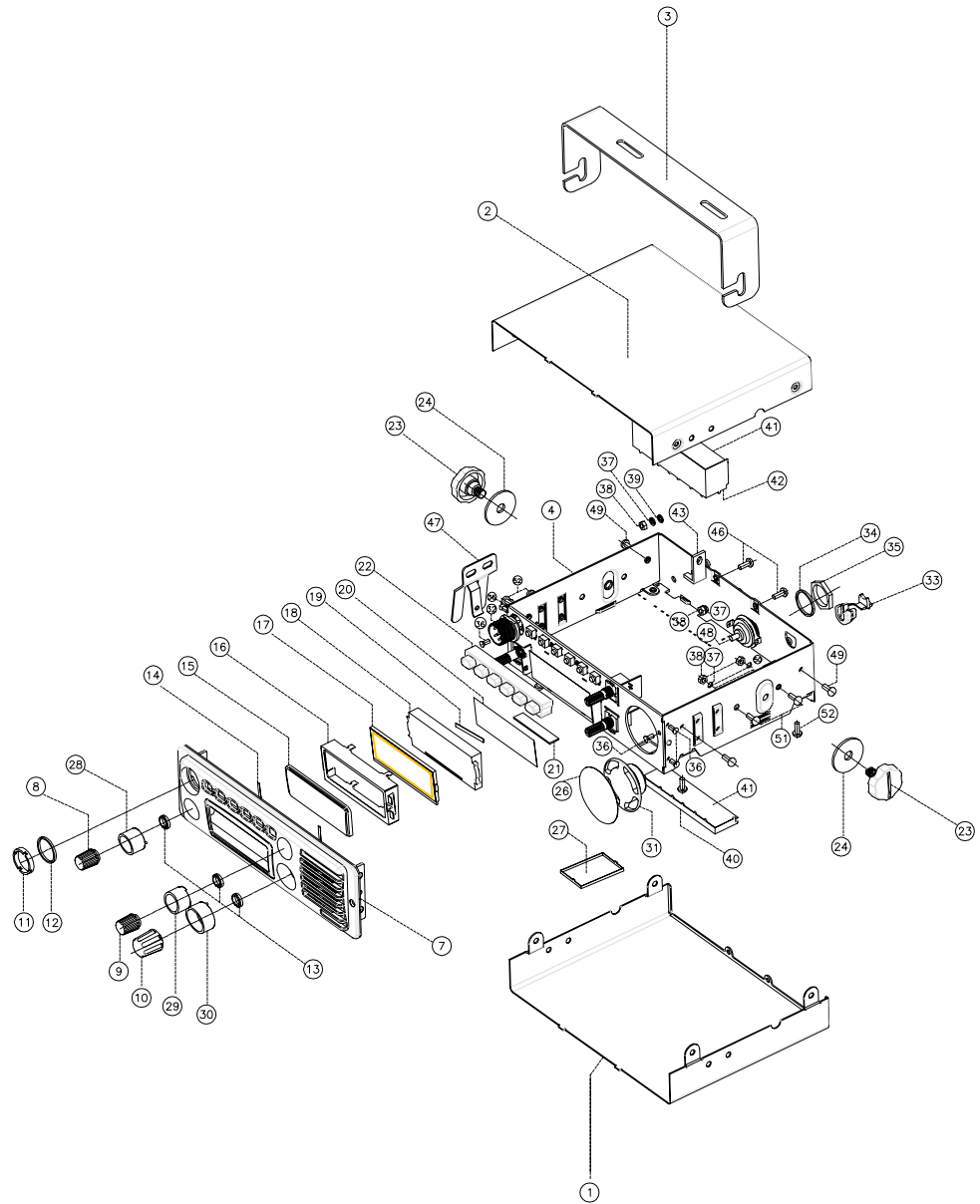
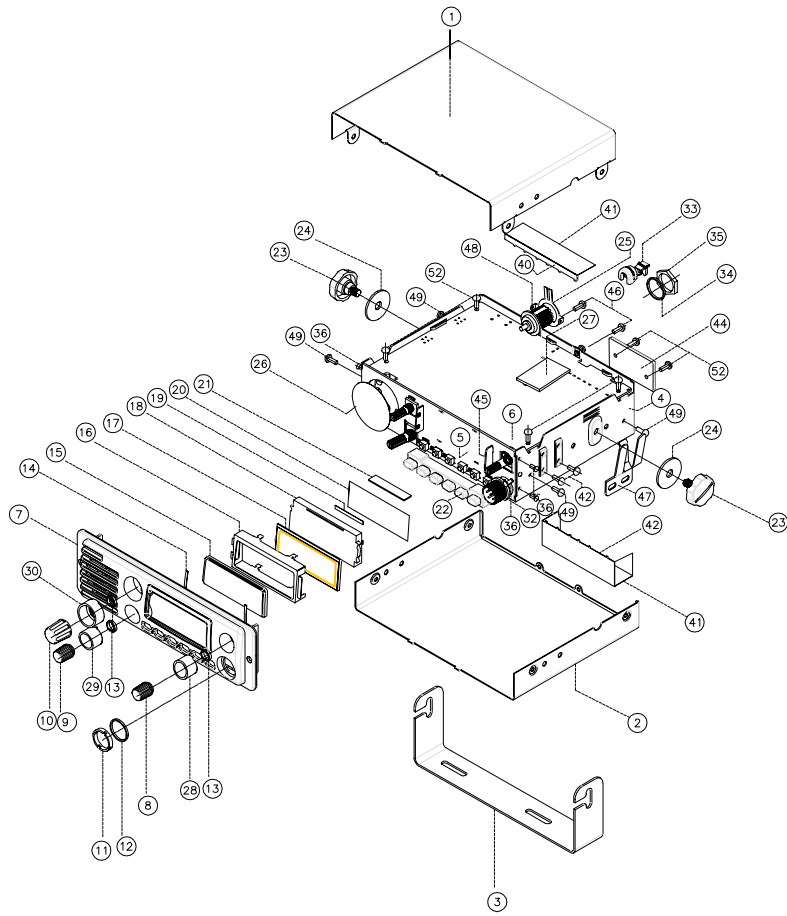

NO	PART NAME	DESCRIPTION	QTY	REMARK
1	Upper cover	SPC 0.8t	1	
2	Bottom cover	SPC 0.8t	1	
3	Bracket(set)	SPC 1.6t	1	
4	Main Body	EGI 1.0t	1	
5	Key PCB	1.6t	1	
6	Main PCB	1.6t	1	
7	Escutcheon	ABS	1	
8	Vol knob	PC	1	
9	Sp knob	PC	1	
10	Ch knob	PC	1	
11	Nut for Mic connector		1	
12	Washer for Mic connector		1	
13	Ring nut	BsBm Ni Plated	3	
14	Window tape		1	
15	Window Lens	Acryl	1	
16	LCD Bracket	SPT 0.4t	1	
17	LCD		1	
18	LCD Diffuser	Acryl	1	
19	Double tape		1	
20	White sheet	64.2x23.1x0.1t	1	
21	Zebra	Silicone 1.0t	1	
22	Keypad	Silicone	1	
23	Stud Bolt	ABS M6x8l	2	For Bracket
24	Packing rubber	Black	1	
25	Ant. terminal	SPT 0.2t	1	
26	Felt (spk)	Ø41.7x0.2t	1	
27	VCO shield can	SPT 0.3t	1	For main pcb
28	Illuminator(Vol)	PC	1	
29	Illuminator(Sq)	PC	1	
30	Illuminator(Ch)	PC	1	
31	Speaker		1	
32	Mic connector		1	
33	Cord stopper	PP Black	1	
34	Washer for Ant. connector		1	
35	Nut for Ant. connector		1	For TR
36	Screw mach(+)	M2.6x5L Ni plated FH	6	For cover
37	Spring washer	M3 Ni plated	4	For TR
38	Nut	M3 SS41 Ni Plated	4	For Main body
39	Insulation washer	Paper Ø3.0	1	For TR
40	TX top bracket	SPT 0.4t	1	
41	TX bottom plate	SPT 0.4t	1	
42	TX bottom bracket	SPT 0.4t	1	
43	Heat sink	Aluminum 2.0t	1	
44	Heat sink-2	Aluminum 3.0t	1	
45	Led PCB	1.6t	1	
46	Screw Tap(+)	M3x8L taptite BH	8	For Main body
47	Bracket (Mic.)	SUS304 1.0t	1	
48	Ant. connector		1	
49	Screw Tap(+)	M3x8L Taptite FH	2	
50	TR		1	
51	Screw Tap(+)	M3x10L Taptite BH	2	For TR
52	Screw Tap(+)	M3x12L Taptite BH	2	For Main body
53	Screw Tap(+)	M3x8L Taptite FH	2	For Mic. Bracket

SECTION 5. BOARD LAYOUT

5-1.Main PCB (Top Side)

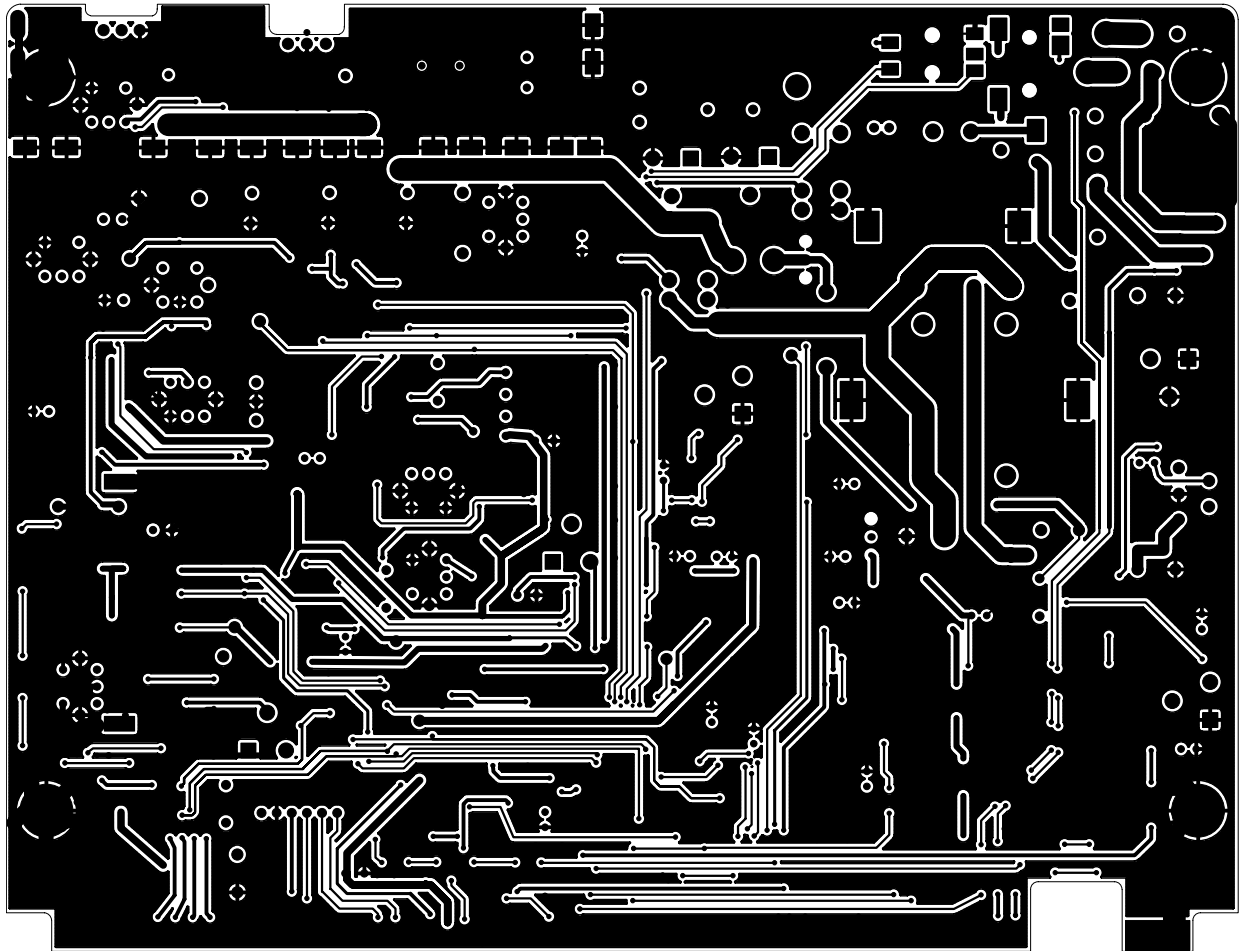

PCB = 1.6 T

Main PCB (Bottom Side)

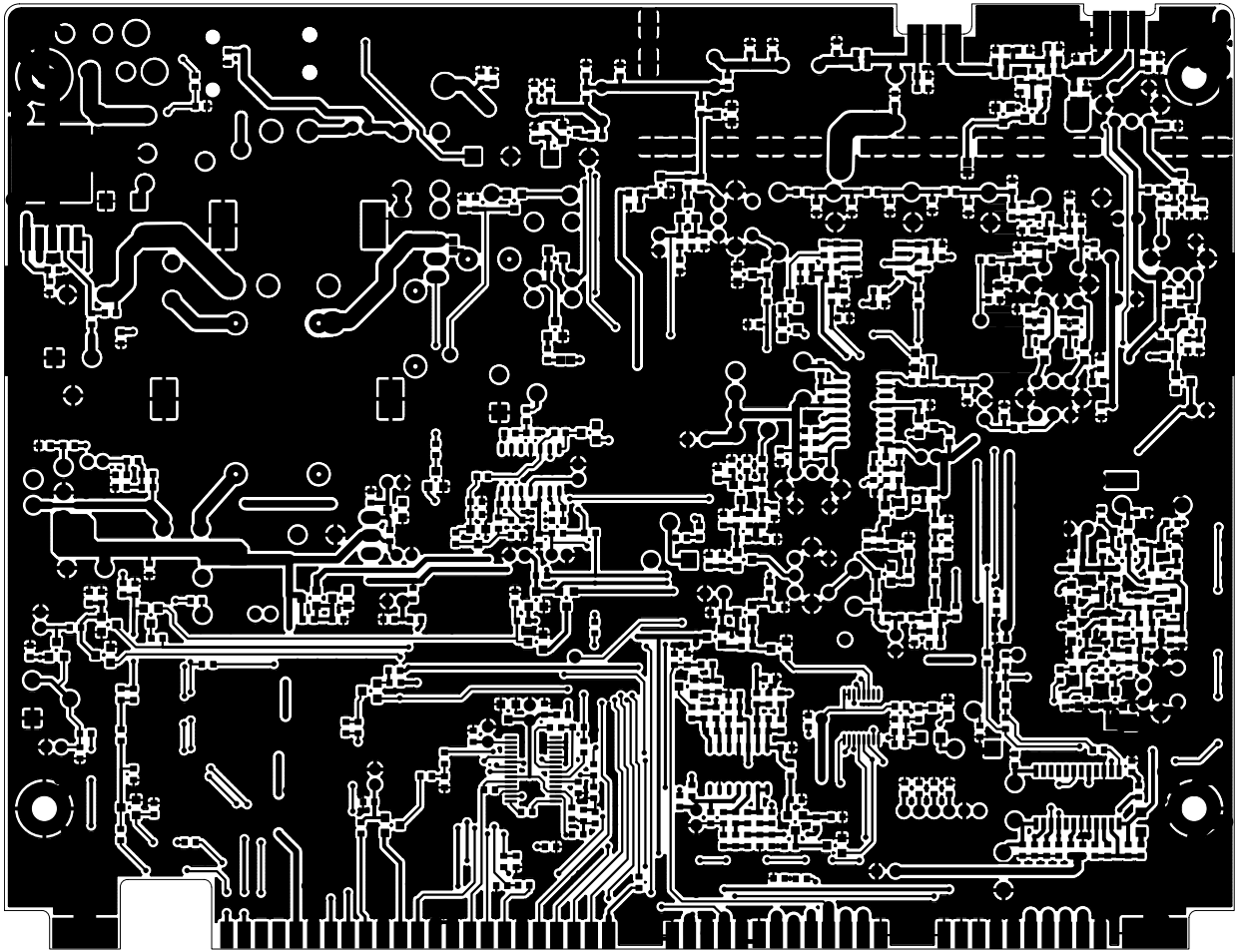

PCB = 1.0 T

5-2. LCD PCB (Top Side)

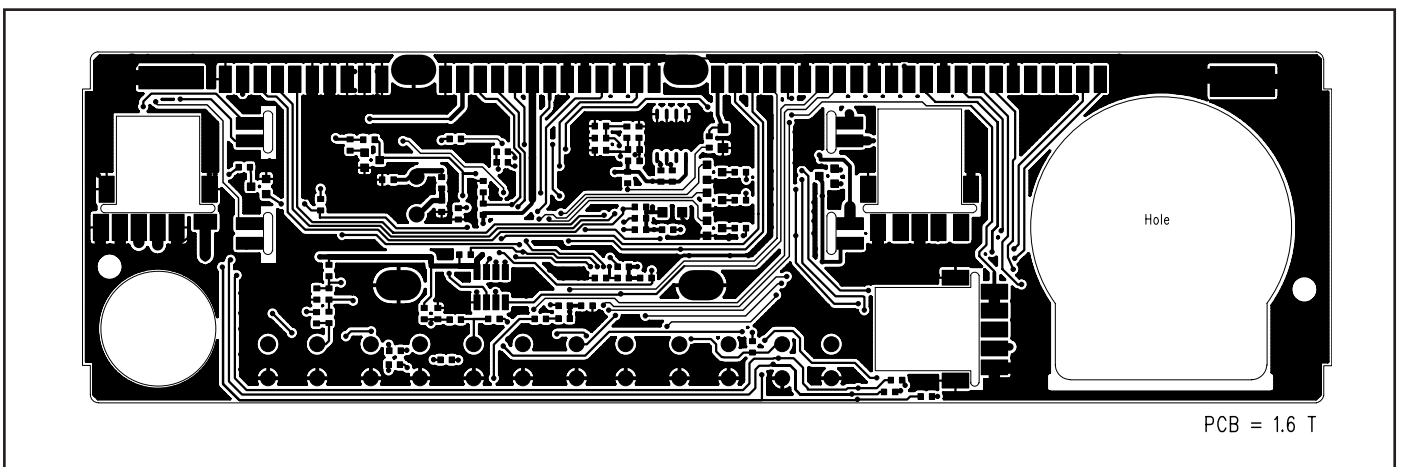

LCD PCB (Bottom Side)

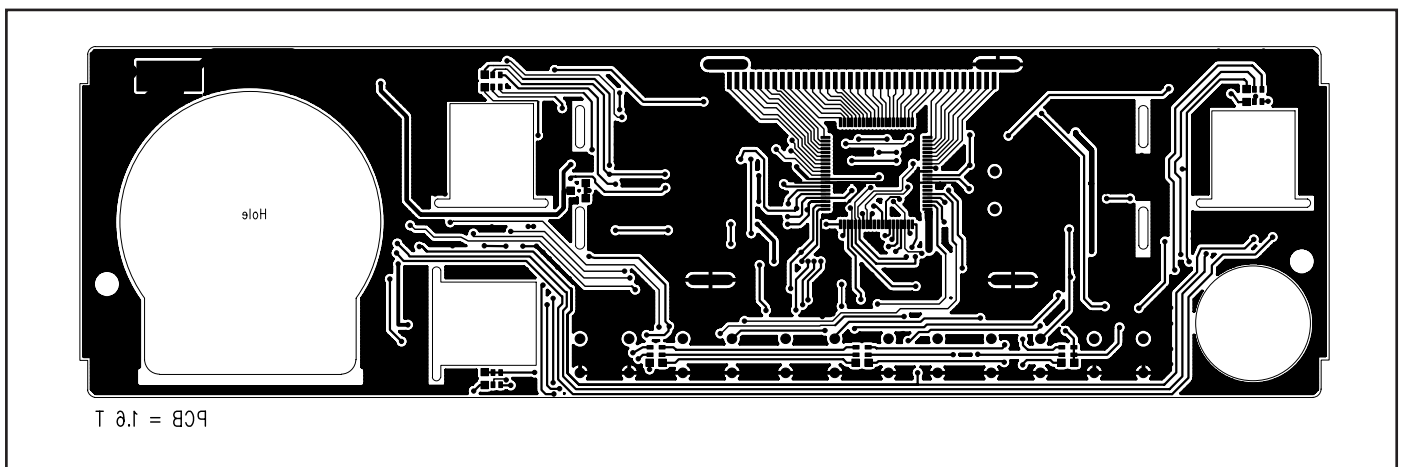

5-3. LED PCB (Top Side)

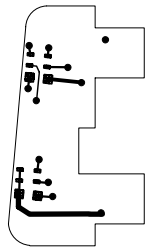

PCB = 1.0 T

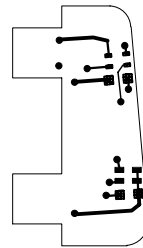

PCB = 1.0 T

LED PCB (Bottom Side)

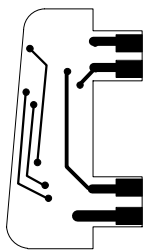

PCB = 1.0.1

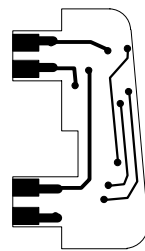

PCB = 1.0.1

5-4. Volume PCB (Top Side)

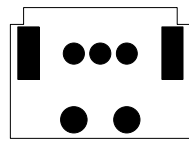

PCB = 1.0 T

Volume PCB (Bottom Side)

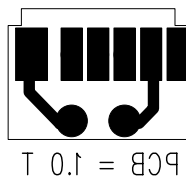

5-5. Squelch PCB (Top Side)

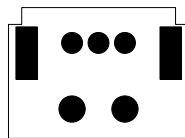

PCB = 1.0 T

Squelch PCB (Bottom Side)

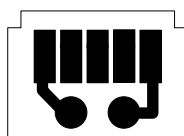

PCB = 1.0 T

5-6. Channel PCB (Top Side)

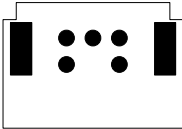

PCB = 1.0 T

Channel PCB (Bottom Side)

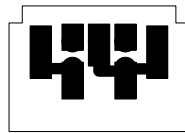

PCB = 1.0 T

SECTION 6. BLOCK DIAGRAM

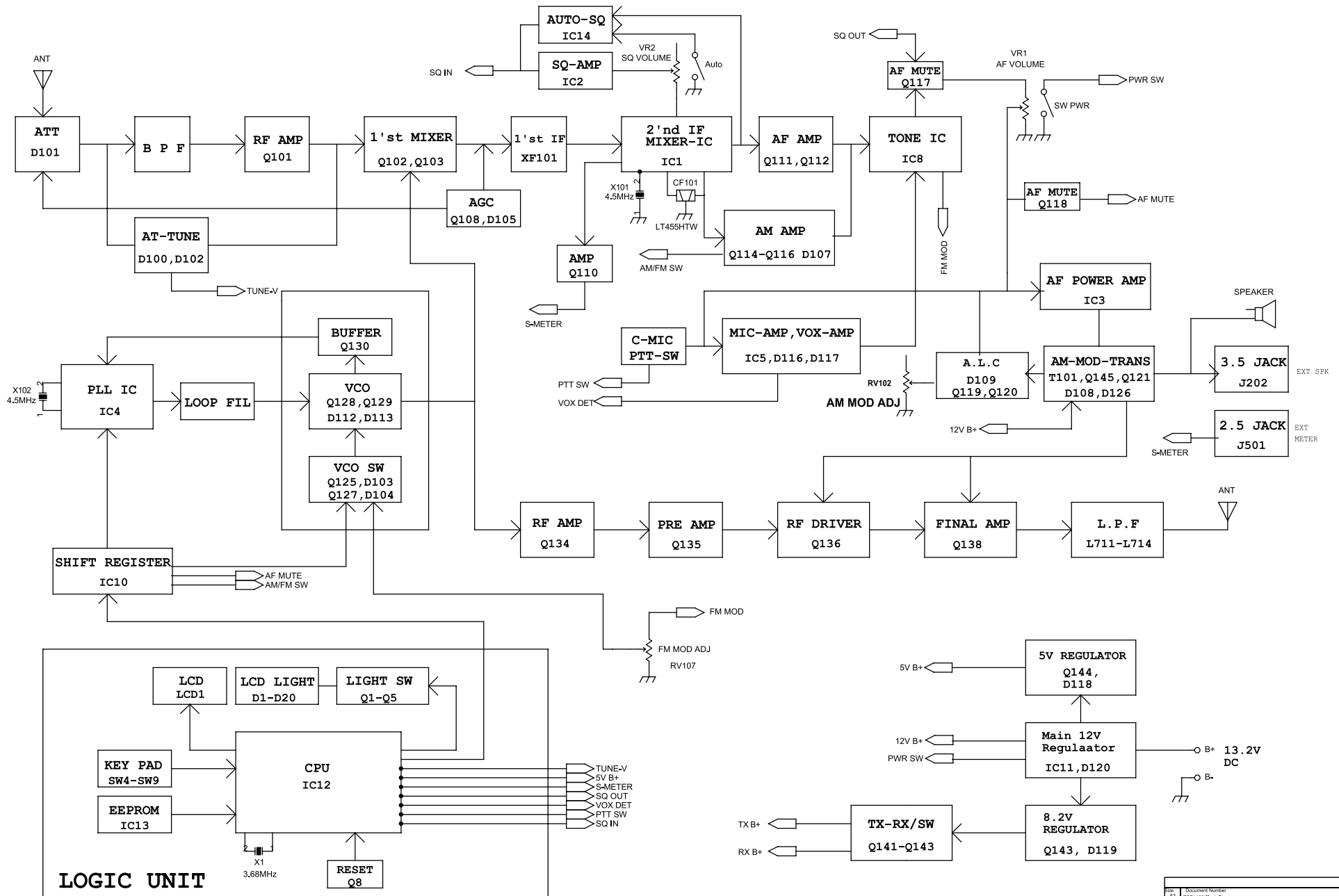

SECTION 7. SCHAMATIC

